



NEW ENERGY RECOVERY WHEELS FOR CUSTOM AND SEMI-CUSTOM AIR HANDLERS

MULTIPLE PERFORMANCE OPTIONS ALLOW YOU TO CHOOSE YOUR DESIGN PRIORITY

- Low Air Pressure Drop
- High Thermal Energy Performance
- Best Recovered Energy Ratio (RER)

FEATURES & BENEFITS

STAINLESS STEEL WHEEL Provides superior strength and will not corrode.

DURABLE POLYMER ENERGY TRANSFER MATERIAL Withstands harsh coastal and pool environments.

MECHANICALLY BONDED DESICCANT Will not wash off or degrade during the cleaning process.

EASILY REMOVABLE SEGMENTS Effectively ensure optimal performance for the life of the system.

REDUCED WEIGHT Up to 50% less than competition.

COMPACT DESIGN Reduces air handling unit height by up to 12 inches for reduced shipping expense and mechanical room layout.

LOWEST LIFECYCLE COST Service friendly design ensures low maintenance cost for life of air handling unit.



**ERC-118C
SERIES**
15,000-
45,000 CFM



PERFORMANCE

DIMENSIONS & OPTIONS		
Dimensions (in)	A	126
	B	126
	C	14
Weight (lbs)	1325	
Electrical Options	208-230V/460/575V/3ph	
Motor	1.5 hp, VFD Compatible	
Effectiveness (%)	50 to 80% Total	
Airflow Range	15,000 to 45,000 CFM	
Energy Transfer	Sensible or Enthalpy	
Frame Options	Powder Coat	
	Double Wall Construction	
Desiccant Options	Silica Gel	
	Molecular Sieve	

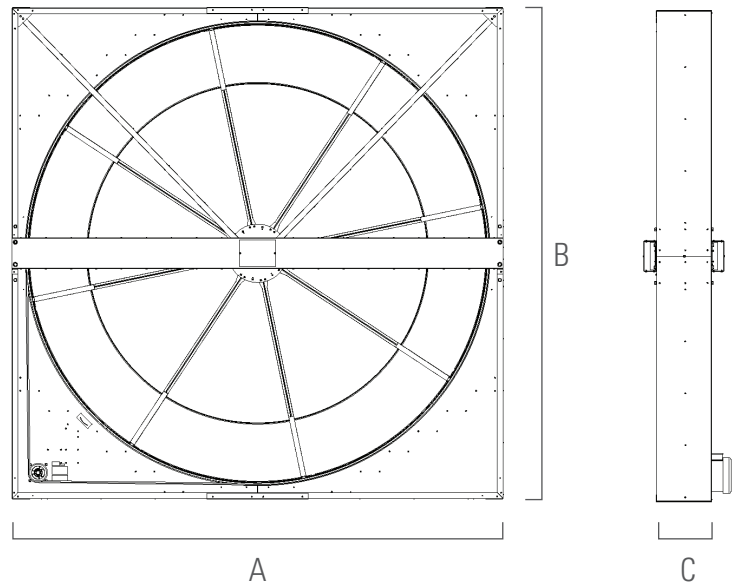

SIZE 118"

AIRFLOW UP TO
45,000 CFM



MODEL	AIR FLOW RANGE (CFM)	TOTAL EFFECT.	Recovered Energy Ratio (RER) (BTU/WATT)	PERFORMANCE PROFILE	EFFECTIVENESS	AIR PRESSURE DROP
ERC-118260C	15,000-35,000	50-80%	Up to 100	HX MATRIX	Best	Good
ERC-118340C	15,000-40,000			OPTI MATRIX	Better	Better
ERC-118360C	15,000-45,000			FX MATRIX	Good	Best

